

Installation

ULTRAFLOW® type 65-S/65-R

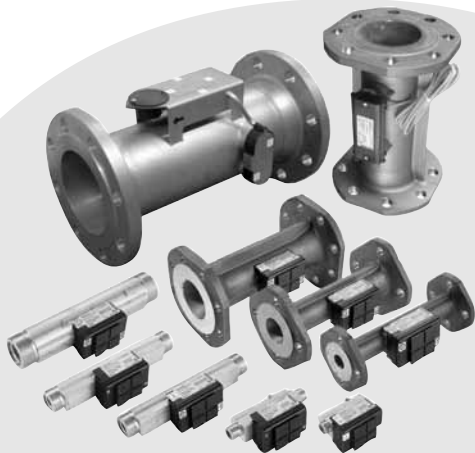

Kamstrup

Kamstrup A/S
Industrivej 28, Stilling
DK-8660 Skanderborg
TEL.: +45 89 93 10 00
FAX: +45 89 93 10 01
info@kamstrup.com
www.kamstrup.com

1. Installation

Prior to installation of the flow sensor, the system should be flushed, and protection plugs/plastic diaphragms on the flow sensor should be removed. Correct placing of the flow sensor (flow and return) will appear from the front label of MULTICAL®.

The flow direction is indicated by an arrow on the side of the *flow sensor*.

Glands and gaskets are mounted as shown in the drawings overleaf.

Pressure stage of

ULTRAFLOW® type 65-S/R: PN16/PN25/PN40, see marking.
Flow sensor marking does not cover included accessories.

Temp. of medium,

ULTRAFLOW® type 65-S/R: 15...130°C

Mechanical environment: M1 (fixed installation with minimum vibration).

Electromagnetic environment: E1 (housing/light industry). The meter's control cables must be drawn at min. 25 cm distance from other installations.

Climatic environment: Installation must take place in environments with non-condensing humidity as well as in a closed locations (indoors). The ambient temperature must be within 5...55°C.

Maintenance and repair: The flow sensor is verified separately and can, therefore, be separated from the calculator. Battery for replacement: Kamstrup type 66-00-200-100. Other repairs require subsequent reverification in an accredited laboratory.

ULTRAFLOW® can only be connected direct to Kamstrup's calculators on terminals 11-9-10, as shown in section 5.3. Connection to other types of calculators require the use of a pulse transmitter.

Note: Please make sure that "pulse/litres" is identical on flow meter and calculator.

If the temperature of the medium exceeds 90°C, we recommend the use of flange meters as well as wall mounting of MULTICAL®.

In order to prevent cavitation the working pressure at ULTRAFLOW® must be min. 1.5 bar at qp and min. 2.5 bar at qs (4.5 bar for DN80). This applies to temperatures up to approx. 80°C. ULTRAFLOW® must not be exposed to lower pressure than the ambient pressure (vacuum).

When the installation is complete, the water flow can be turned on. The valve on the inlet side must be opened first.

1.1 Installation angle for ULTRAFLOW®

ULTRAFLOW® ≤ DN100

ULTRAFLOW® can be mounted horizontally, vertically or at an angle.

⚠ Important! In connection with ULTRAFLOW® ≤ DN100, the plastic box containing the electronics must be placed on the side (when installed horizontally).

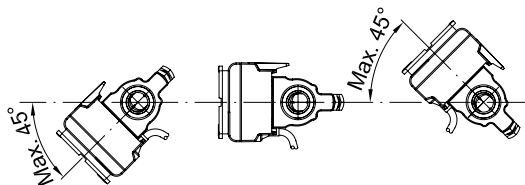
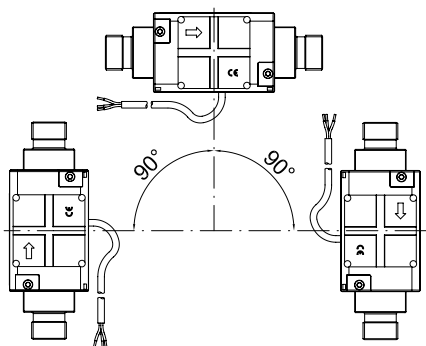

ULTRAFLOW® can be turned up to $\pm 45^\circ$ (in relation to the pipe axis).

ULTRAFLOW® ≥ DN150

ULTRAFLOW® can be mounted horizontally, vertically or at an angle.

⚠ Important! In connection with ULTRAFLOW® ≥ DN150, the box containing the electronics must be placed upwards (when installed horizontally).

ULTRAFLOW® can be turned up to $\pm 45^\circ$ (in relation to the pipe axis).

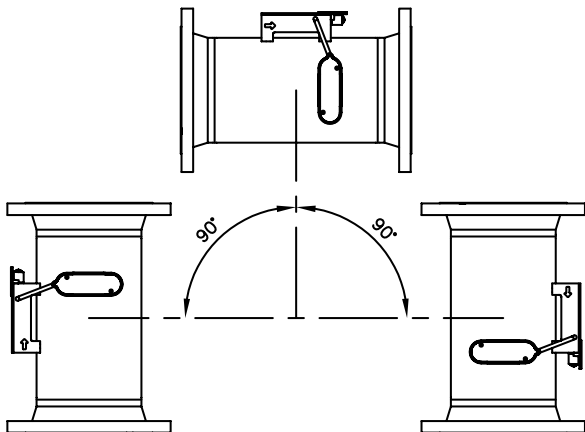

1.2 Straight inlet

Straight inlet: ULTRAFLOW® requires neither straight inlet nor outlet to meet the Measuring Instruments Directive (MID) 2004/22/EEC, OIML R75:2002 and EN 1434:2007. Only in case of heavy flow disturbances before the meter will a straight inlet section be necessary. We recommend to follow the guidelines in CEN CR 13582.

2. Examples of installation

Threaded meter with MULTICAL®/PULSE TRANSMITTER mounted on ULTRAFLOW®.

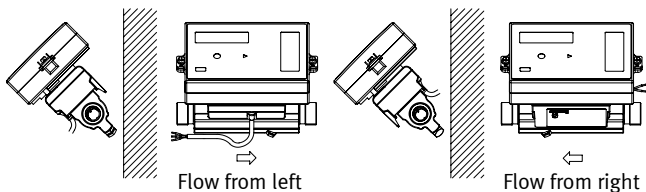

Short direct sensor mounted in ULTRAFLOW® (only G $\frac{3}{4}$ (R $\frac{1}{2}$) and G1 (R $\frac{3}{4}$)) and glands fitted on the meter.

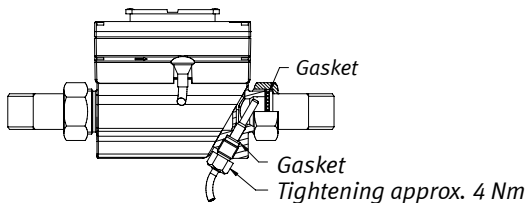

Flange meter with MULTICAL®/PULSE TRANSMITTER mounted on ULTRAFLOW®.

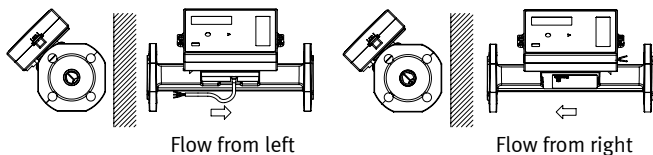

Please note: For meters \geq DN100, MULTICAL® or PULSE TRANSMITTER cannot be mounted on the flow part.

3. Electric connection

ULTRAFLOW®	→	MULTICAL® MAXICAL III
Blue (GND)/11A	→	11
Red (supply) 9A	→	9
Yellow (signal)/10A	→	10

Connection:
MULTICAL®/MAXICAL and ULTRAFLOW®
(ULTRAFLOW® is supplied from
MULTICAL®/MAXICAL).

4. Voltage supply of PULSE TRANSMITTER

The PULSE TRANSMITTER can be supplied through a built-in lithium battery, a 24 VAC internal mains module or an internal 230 VAC mains module.

The two wires on the battery or the mains module are mounted in terminal strips nos. 60 and 61.

⚠ The polarity must be correct; red wire to terminal no. 60 (+) and black wire to terminal no. 61 (-).

4.1 Battery supply

The PULSE TRANSMITTER is connected to a lithium battery, D-cell. The battery is marked with installation year, e.g. 2007, and manufacturing date.

Optimal battery lifetime is obtained by keeping the battery temperature below 30°C, e.g. in connection with wall-mounting.

The voltage of a lithium battery is almost constant throughout the entire battery lifetime (approx. 3.65 V). Thus, it is not possible to measure the remaining capacity of the battery.

The battery must neither be charged nor short-circuited. Used batteries must be disposed of with consideration to the environment.

4.2 Mains modules

The modules are under protection class II and are connected through a two-wire cable (without ground) through the cable nipple of the calculator, which is placed at the bottom on the right-hand side of the base unit. Use a feeder cable with an outer diameter of 5–10 mm and ensure correct dismantling and mounting of cable relief. Max. permitted fuse: 6 A

Note! National regulations covering installations must be obeyed.

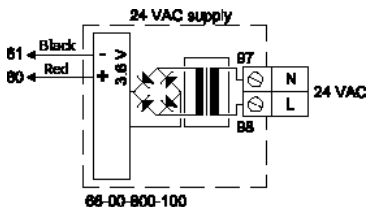

24 VAC

A transformer, e.g. type 66-99-403 for 24 VAC supply module must be used.

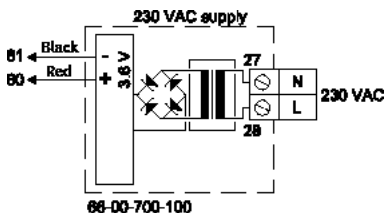

230 VAC

In connection with direct mains connection this module must be used.

⚠ NB:

External supply must only be connected to the supply module.

5. Electric connection through PULSE TRANSMITTER

ULTRAFLOW® → PULSE TRANSMITTER → MULTICAL®

	In	Out	
Blue (GND)/11A →	11	11A →	11
Red (supply) 9A →	9	9A →	9
Yellow (signal)/10A →	10	10A →	10

ULTRAFLOW® → PULSE TRANSMITTER → MAXICAL III

	In	Out	
Blue (GND)/11A →	11	11A →	11
Red (supply) 9A →	9		
Yellow (signal)/10A →	10	10A →	10

When long control cables are used, please act with care when installing. Control cables must be installed with not less than a 25 cm distance to other cables due to EMC.

5.1 Electric connection

Connection to the PULSE TRANSMITTER

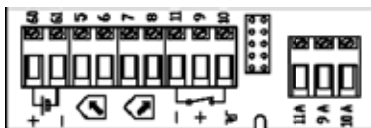

5.2 Block diagram

The PULSE TRANSMITTER outlet

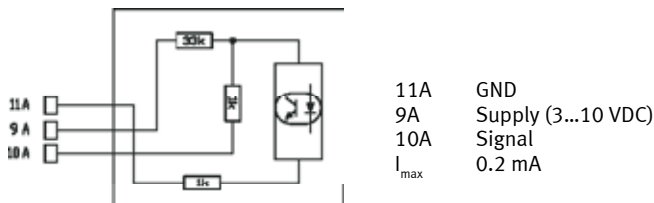

5.3 Connection example

Example of connection between ULTRAFLOW® and MULTICAL® (battery supply).

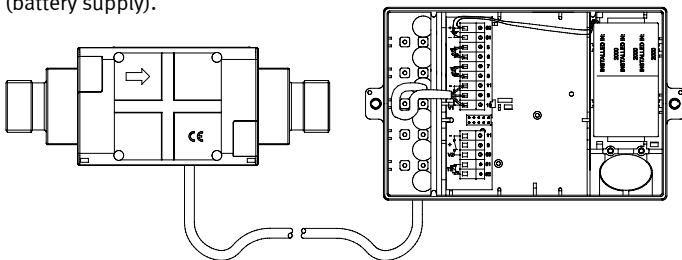

6. Functional control

A functional control must be made, when installation of the entire energy meter is completed. Open thermostats and drain cocks to make the water flow in the heating system. Check that display values for temperature and water flow are reliable.